



## Lollipop Flat Nappies

Flat nappies are an economic nappy and can be fastened with a 'nappi nippa' rather than a pin for greater confidence at change time. The nappy nippa simply hooks into the towelling loops and avoids the risk of pins pricking the baby (and you!). Can be folded into a variety of styles or pad folded for use in a pocket nappy. They can be used in a range of covers (always with a leg gusset!) and open out for quicker drying.

These are also really useful as boosters to be used with other nappies if necessary. An essential part of Hunnybums nappy kit even though we rarely use them as nappies - great on changing mats, during potty training, changing the oil on the car.....

Traditional terry towelling fabric in 100% cotton. Pack of 12.

\*Regular : 60cm x 60cm



### Hunny Highlights

- ✓ Superb value for money
- ✓ Good if drying facilities limited
- ✓ Full control over the fabric against baby's skin
- ✓ Variety of folds to suit baby
- ✓ Can have second career after baby grows up as dusters etc!
- ✓ Two part system offers good containment
- ✓ Ideal for travelling - can pack flat

### Nappy Do

- ✓ Always use a cover with a leg gusset - essential for containment
- ✓ Wash the nappy after each use
- ✓ The wrap can usually be used again - simply wipe clean on the inside
- ✓ Store in a dry bucket (or you can soak)
- ✓ See [Washing and Drying](#) info sheet
- ✓ Wash at 40 - 60 °C (you can wash at higher temperatures if you prefer but it's not necessary) in non-bio detergent plus sanitiser
- ✓ Nappies can be line dried, aired indoors or tumble dried on a low setting

### Hunny Heads-up

- ! More fiddly than shaped nappies as you have to fold them first
- ! May be difficult to put on a wriggling toddler
- ! A separate waterproof cover is needed
- ! May need boosting for older children

### Nappy Don't

- ! Do not use nappy creams/ointments without a paper liner to protect the nappy (See [Nappy Rash](#) info sheet)
- ! Do not use chlorine bleach, borax, fabric conditioners or biological detergents
- ! Do not tumble dry covers

### Hunny Hints

- ✓ See our 'folding guide' for more information on different folds (on the next page)



## Folding Flat Nappies

All of the following nappy folds can be fastened with either pins or Nappi Nippas. I recommend Nappi Nippas as they cannot prick your baby (or you!), are easy to use and do not weaken the terry fabric as pins do.

### Newborn Fold

Ideal for use on newborn babies, especially boys, as the padding is at the front. Works best with a muslin square containing a booster pad rather than a terry, which is a bit bulky. This fold also provides a dip at the front around the healing navel area.

1. Fold muslin into a triangle.
2. Fold this triangle into a smaller triangle and turn so that long edge is away from you. Add a booster in the middle at this stage, if desired, lined up against the straight edge.
3. Bring up the front point of the nappy, containing the booster up between baby's legs.
4. Bring both sides over the front.
5. Fold down the side points to provide extra thickness at the front.
6. Pin or Nappi Nippa through the muslin only (not the booster).
7. (Not shown) Tuck excess fabric up at the legs to improve containment.

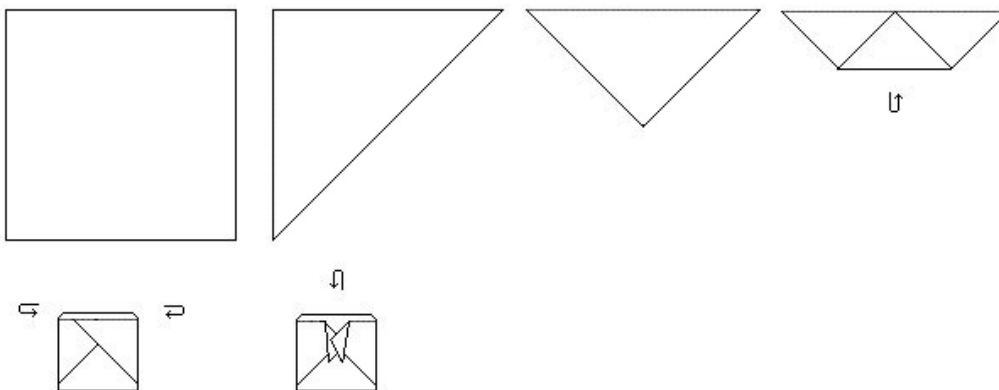

## Girls' Fold

As this gives a very trim fit around the legs and upper thighs, it is probably better for a girl than a boy. Although complicated at first, becomes easy with practise!

1. Place nappy in front of you.
2. Bring top corner down to bottom corner and then overlap by about 4 inches.
3. Take bottom corner **a** back up, folding nappy at **b** (other dotted line is underneath).
4. Fold **c** over to **d** to give a triangle with a bit sticking out!
5. Tuck the ends in (point **y**) to make it tidier.
6. Put baby's bottom on **x** with legs astride **y**, bring **y** up between legs, and bring corners **z** around waist to pin or Nappi Nippa.

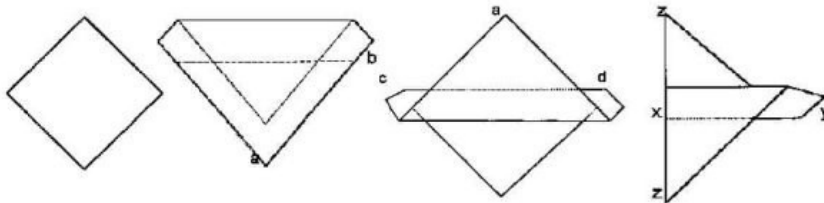

## The Kite Fold

This is quite a large fold, more bulky round the legs. It has limited absorbency, but is good to use to support a booster pad for overnight use. When on, tuck terry in around the legs to provide better containment and a neater fit.

1. Lay terry flat, and imagine a diagonal line running from top left to bottom right corner.
2. Fold bottom left and top right corners in to meet on your imaginary line.
3. Fold top left corner down towards bottom right.
4. Fold bottom right corner up as far as needed, adjust to suit baby's size.

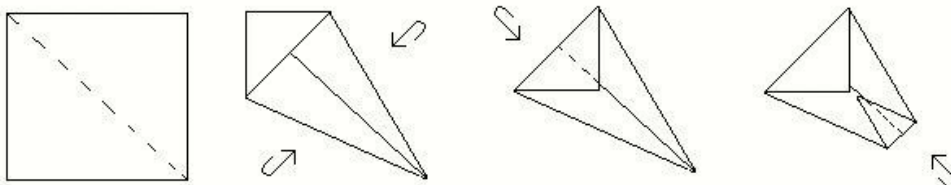

## The Bat/Butterfly/Chinese/Angel Fold

This is another fold that is good for newborns. Small yet all encompassing, helps to contain runny poo and very absorbent.

1. Fold terry into quarters, have corners at the top left.
2. Using left hand, hold down bottom 3 corners.
3. With right hand pull top corner out to the side.
4. Without disturbing the folds, turn the whole nappy over.
5. Fold one third of the square part in. The distance remaining should be half of the amount folded.
6. Turn nappy round so the bottom of the triangle goes between baby's legs.

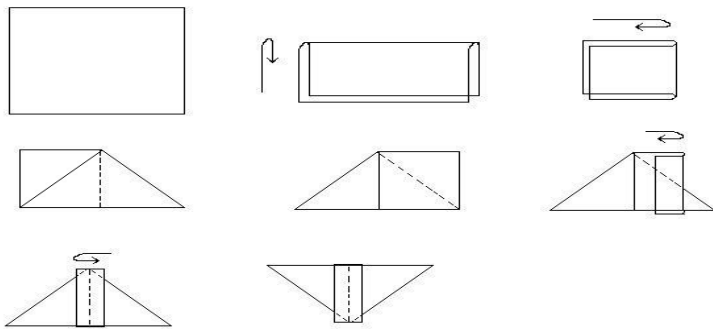

## The "Poo Catcher"

Does what it says! Good for pre-weaning babies.

1. Lay the terry flat in front of you and fold down approximately 1/4 along the back end.
2. Fold in 1/3 from the left and then 1/3 in from the right.
3. Holding this pad lightly about halfway down on the left, fold out the right flap and do the same for the left flap underneath.
4. Fold up the front end as much as is required for your baby's size.

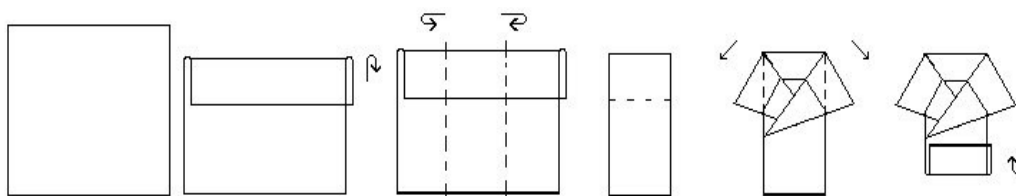

## The Pad Fold

Good for older babies (4-5 months plus) used inside any Velcro-fastening gusseted wraps. Very absorbent, yet neat: no excess fabric over baby's hips. Excellent inside another shape folded terry as a mighty booster for an overnight nappy. May suit a boy best, as thicker fold is at one end.

1. Fold over the top 1/3 (along a horizontal line).
2. Fold the nappy into quarters or thirds depending on the width of nappy required.

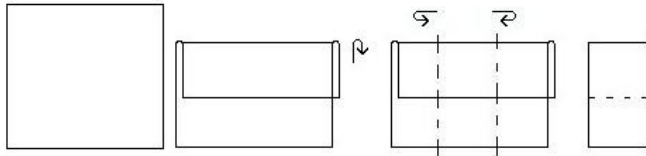

## The Neat Fold

Essentially the same as the kite, just folded in a different order.

1. Lay terry flat, so that a corner is nearest you.
2. Fold the top and bottom corners towards the centre. How far you fold depends on the size of nappy required.
3. Fold the right and left corners in to meet at the middle of the waistband (uppermost) edge.

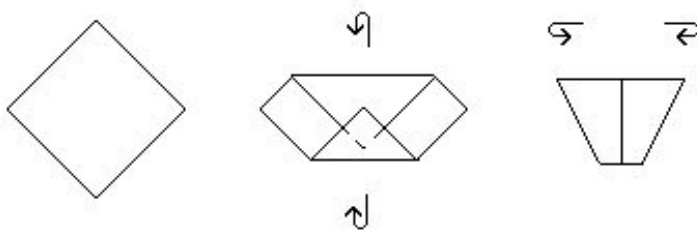

## The Jo Fold

This one enables you to put even the thickest 60cm terry on a newborn child, without adding too much bulk (because it spreads it so evenly). So it's an ideal fold when you only want to buy one size of flat terry. It also works fantastically with muslins instead of terries.

Fold all four points to the centre.

Fold each side over one third.

Fan out the top of the nappy, holding where indicated in diagram 3

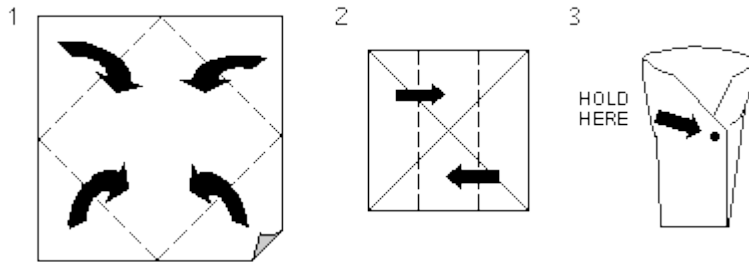

## The V Fold

Fold three sides to the centre.

Fold top down to overlap the centre.

Fold bottom corners as shown in diagrams 3 & 4.

